

1550nm ELED Module

1550nm ELED Module

Features

- High coupled power
- Peak wavelength 1550 nm
- 3 dB bandwidth >40 nm
- Cut off frequency > 150 MHz
- Operating temperature range 0°C to 70°C
- Hermetically sealed TO package in pigtailed, receptacle housing with FC, ST or SC, or sugar cube with ST

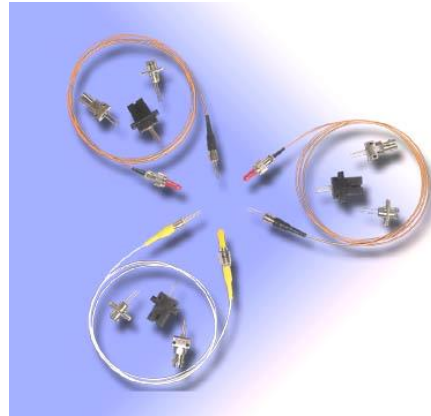

Specifications (100mA forward current, 25 °C)

Parameter	Symbol	Min	Typical	Max	Units
Peak Wavelength	λ	1520	1550	1580	nm
Spectral width FWHM	$\Delta\lambda$	40	-	-	nm
Coupled power to 62.5 μm fiber	Po	300	-	-	μW
Coupled power to 50 μm fiber	Po	300	-	-	μW
Coupled power to 9 μm fiber	Po	100	-	-	μW
Forward voltage	V_F	-	-	2	V
Rise/fall time (10% to 90%)	tr/tf	-	-	3	ns
Cut off frequency (Iop=100 mA, 20mA p-p)	B	150	-	-	Mb/s

Absolute Maximum Ratings

Parameter	Symbol	Min.	Max.	Unit
Operating temperature	To	0	+70	°C
Storage temperature	T _{stg}	-40	+85	°C
Reverse voltage	V _R	-	2	V
Forward current	Iop	-	150	mA
Lead Soldering Temperature (10sec)	T _L	-	260	°C

1550nm ELED Module

Ordering Information

SD15□□□□□□□□-4

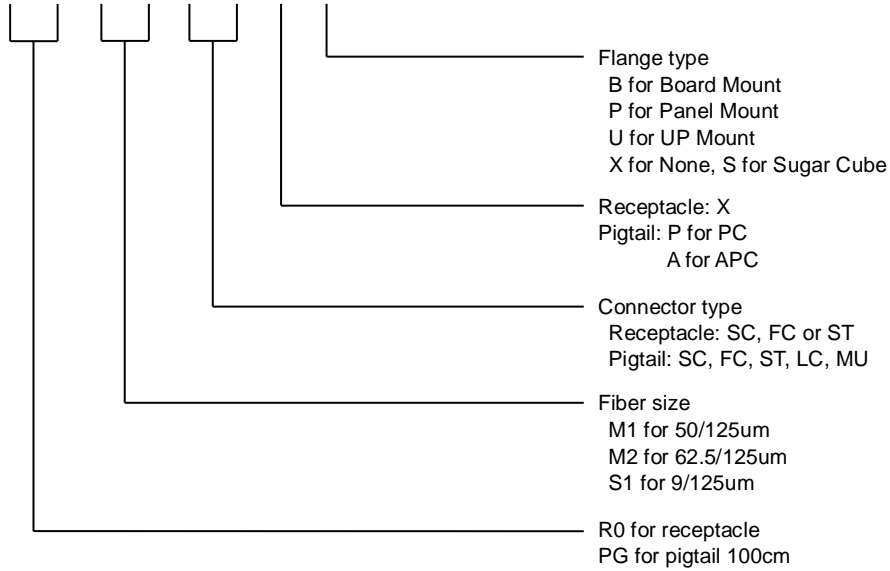

Pin Connections

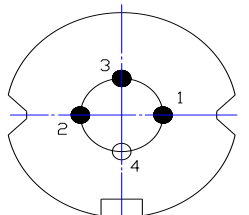

BOTTOM VIEW

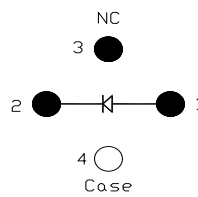

1550nm ELED Module

Dimension

Pigtail Type

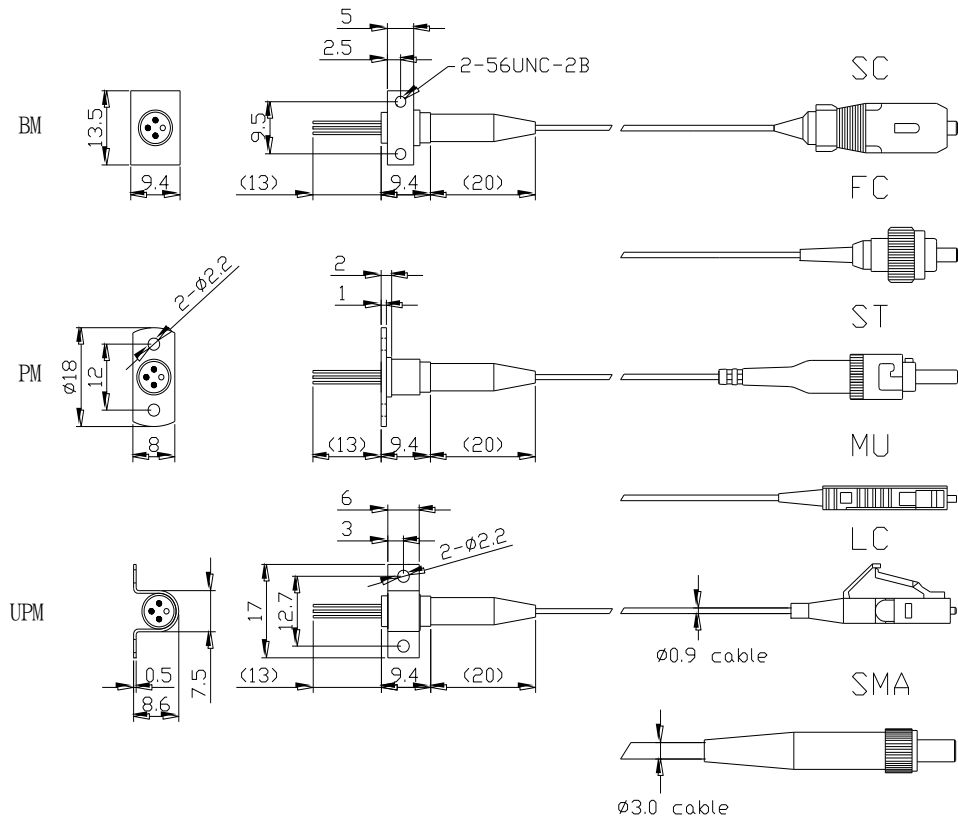

1550nm ELED Module

Receptacle Type

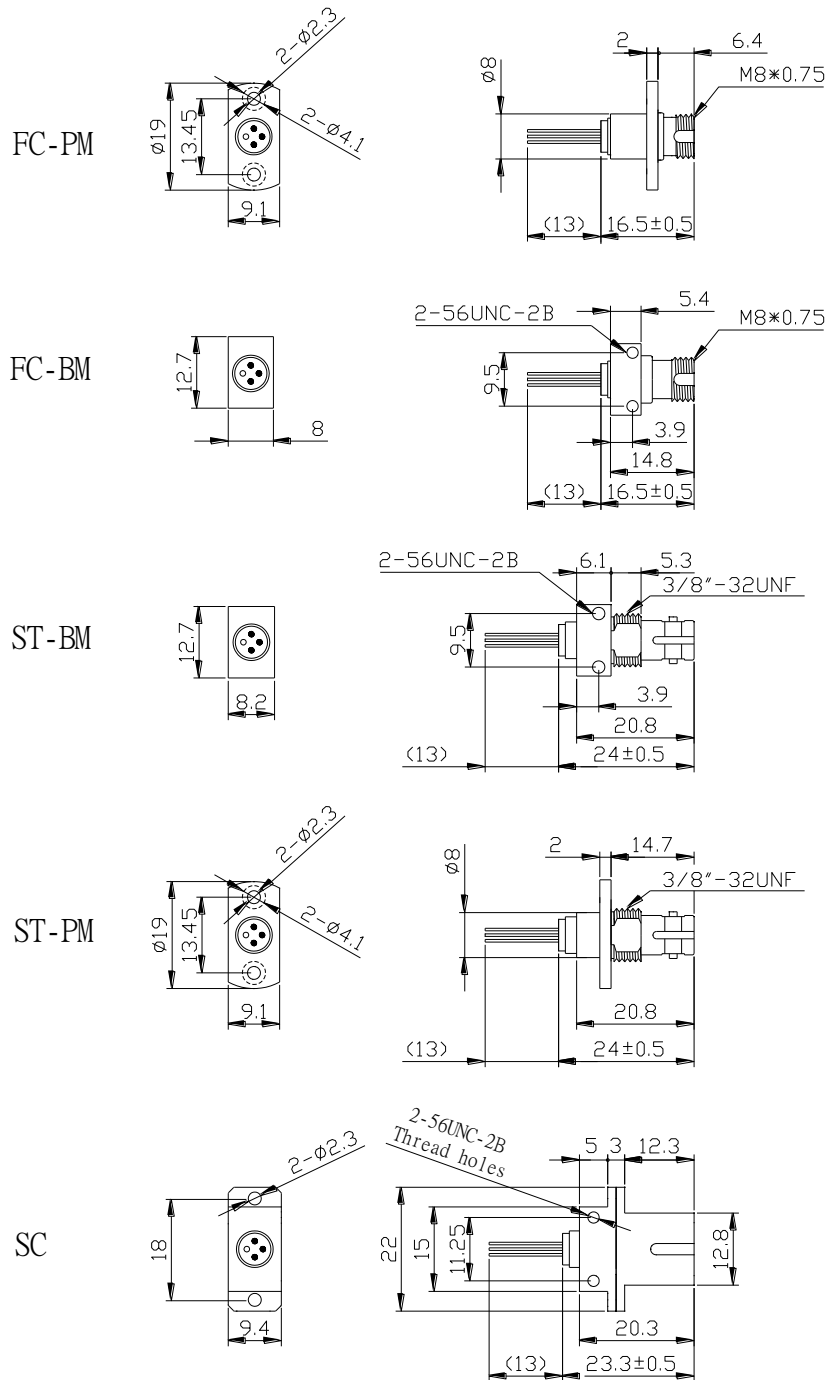

1550nm ELED Module

Sugar Cube

Pin Connections:

PIN No.	FUNCTION
1	ANODE
2	CATHODE
3	ANODE
4	ANODE

Dimension (ST Receptacle):

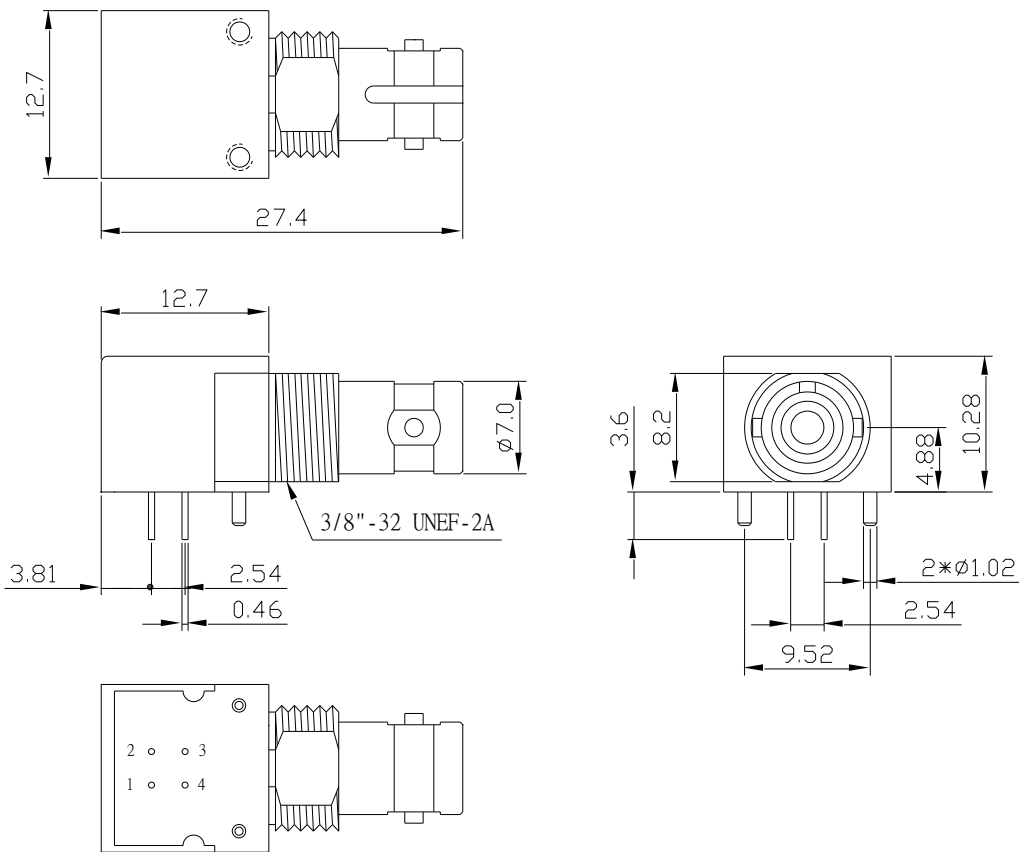

Units:mm

1550nm ELED Module

1550nm ELED Module Power-Iop Curve

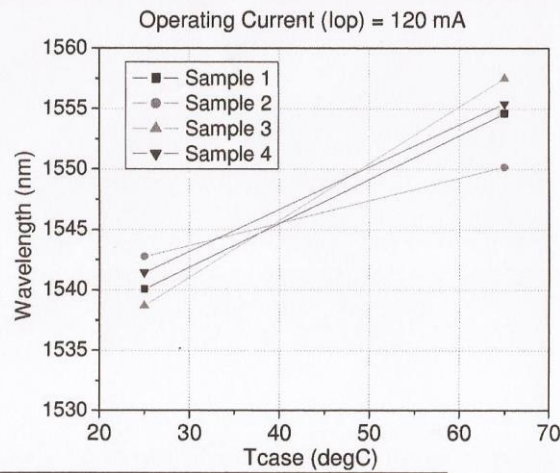
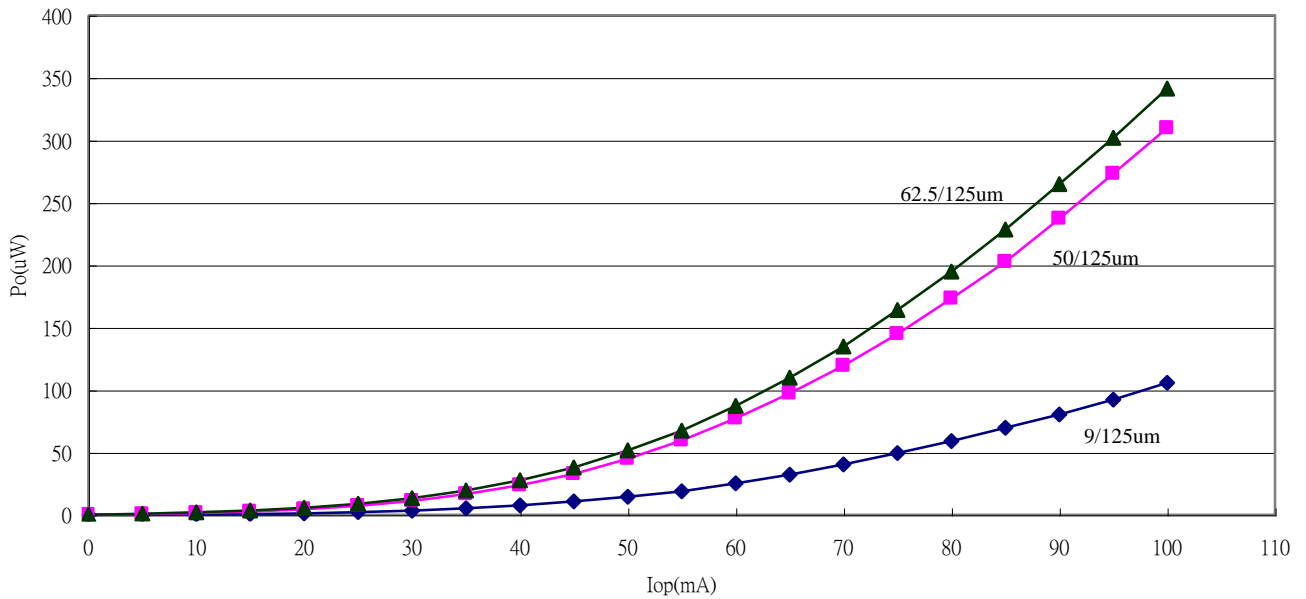

Tcase [degC]	Peak wavelength [nm]			
	Sample 1	Sample 2	Sample 3	Sample 4
25	1540.08	1542.78	1538.73	1541.46
65	1554.59	1550.16	1557.52	1555.42
$\Delta\lambda / \Delta T$ [nm/degC]	0.363	0.185	0.470	0.349
$(\Delta\lambda / \lambda_{25degC}) / \Delta T$ [ppm/degC]	235.54	119.59	305.28	226.41

Mean ($\Delta\lambda / \Delta T$) = 0.342 nm/degC
 Mean $((\Delta\lambda / \lambda_{25degC}) / \Delta T)$ = 221.71 ppm/degC

1550nm ELED Module

